



Article

High Altitude Platform Stations Aided Cloud-Computing Solution for Rural-Environment IoT Applications

Victor Monzon Baeza^{1,*}, and Manuel Alvarez Marban²

¹SIGCOM Group, Interdisciplinary Centre for Security Reliability and Trust (SnT), University of Luxembourg, Luxembourg, Luxembourg

²Engineers Team, Future Connections, Málaga, Spain

E-mail: victor.monzon@uni.lu

Received: 28 October 2022; **Revised:** 20 December 2022; **Accepted:** 26 December 2022

Abstract: This work proposes a flexible and scalable Smart Rural (SR) system for gathering and processing IoT data from remote rural areas with no traditional communication coverage as a handicap. We offer an architecture structured in distinct segments using emerging technologies such as IoT, 5G, Cloud and High Altitude Platform Station (HAPS). This proposal is applied to the rural environment to cover thus all the needs of the system in the collection of IoT data from these remote rural areas, its coverage by space vehicles and its processing and storage through 5G terrestrial networks and cloud services. The proposal includes the deployment of IoT sensors and the development of Amazon Web Services (AWS). On the other hand, the part of the space segment considered by HAPS has been simulated for different space channels. This way offers a complete and automated SR system that allows access to these IoT data from remote rural areas through the Internet.

Keywords: HAPS, IoT, cloud computing, AWS, smart rural

1. Introduction

The agriculture sector has a significant weight in the national economy, contributing to the activity and population of extensive rural areas. The birth of the *Smart Rural* concept [1,2] in parallel to Smart Cities is a consequence of the logical irruption of information and communication technologies (ICT) in the agricultural sector. Digitization to the rural world entails a series of benefits in different areas of farming operations: precision agriculture with the control and/or monitoring of crops and their essential resources, such as water, automation of work and procedures, and in the control and management of livestock, among others. Several projects such as SmartAkis [3], and DEMETER [4] are suggested in Europe for the diffusion of innovative agriculture solutions financed by Horizon 2020 to impulse Smart Rural environments.

Among the emerging technologies, the Internet of Things (IoT) [5] has established itself as essential for agricultural applications [6] thanks to its ability to interconnect any object and data. For example, monitoring soil, water, livestock or pests on plantations, irrigation management, machinery control and diagnosis. The drawback of this case is that we can collect large amounts of data that later require processing. For rural areas, we need infrastructure deployed capable of receiving this enormous amount. In addition, the rural environment has little coverage of wireless technologies. The infrastructure costs involved for operators do not make an investment in these regions attractive. Satellite communications (Satcom) have been the traditional means of extending coverage to remote areas that are difficult to access. Nowadays, Satcom is emerging and gaining a lot of interest in both the industry and the research world thanks to the appearance of mega-constellations. Starlink or OneWeb [7], have entirely renewed the landscape of the world of space communications.

In the appreciated renewal in Satcom, the CubeSats [8] have opened the doors to the use of satellites by both public initiatives and companies, with commercial electronic components and being able to choose many technology providers. As a result, the engineering and development projects for CubeSats have costs that are significantly lower than for other types of satellites, thus extending their use today in Low Earth Orbit (LEO), where there are optimal conditions for data communications, and they are more protected from solar and cosmic radiation. Another key new element for space communications is the High Altitude Platform Station (HAPS) [9]. These aircraft have the origin of taking closer images for better resolution on the surface in Earth observation applications. In addition, they operate in Very Low Earth orbits (VLEO), guaranteeing better performance in terms of data latency, an essential feature when we talk about IoT.

In terrestrial networks, we have the new 5G generation developed by the 3rd Generation Partnership Project (3GPP) that encompasses machine-to-machine (M2M) communications services. These services are also associated with IoT since the basis for data capture is sensor networks. 3GPP since Release 15 [10] proposes the integration of the satellite as another member of the terrestrial networks. In this regard, many challenges arise for such integration addressed in projects such as Sat5G [11], and SATis5G [12], where the integration of the satellite in 5G networks is pursued.

5G networks have also brought with them the virtualization of many services and network elements. One of the current approaches most used in the architecture of computer services and applications is that of microservices. The great advantage of this architecture, which consists, compared to more traditional monolithic architectures, of dividing the function of an application into different services, is that each of these components is as independent as possible from the rest. The provision of these services and computing infrastructure resources on demand or demand through the Internet with a pay-per-use model, Cloud Computing, often called “the cloud” or the cloud, is one of the technologies and services with the most significant recent growth. 80% of companies use Amazon Web Services (AWS) as their primary cloud platform [13].

In this context, we propose a system that unifies sensor-based networks with IoT and communicates with AWS within a 5G network, communicating both ends through HAPS. Three segments are differentiated for designing the smart rural system architecture to transport IoT data from remote rural areas without traditional telecommunications coverage to Amazon cloud services. In this way, improve agricultural systems to transform them into Smart Rural.

The remainder of this paper is organised as follows: Section 2 presents a brief background to this work. Section 3 explains the proposed architecture. In Section 4, the communications protocol is shown. The results are shown in Section 5. Finally, in Section 6, the conclusions are summarized.

2. Background

Satcom is well known as the primary communications system to provide global and secure coverage, independent of any terrestrial disaster that may occur. For this reason, 3GPP, since its Release 15 [10], proposes its integration with the 5G and beyond networks as one more element of the terrestrial networks. Secondly, IoT has raised in the market due to the current era demanding smart and autonomous services and is quickly spreading to various areas such as health care, automation, home, smart mobility, environmental monitoring, and Industry 4.0. We highlight the application of IoT in 5G networks as proposed in [14].

In the literature, we can find several works in which Satcom-assisted IoT technology is being used to deliver data from sensors to the ground segment and core of the network. This combination is proposed for the critical sector, such as the maritime case where V.M. Baeza *et al.* in [15] present an architecture using medium earth orbits (MEO) instead of HAPS as the proposal in this work.

More specifically, an IoT system in the agriculture sector that concerns this work has been proposed in [16] for an irrigation system. However, it does not include data processing, only collection. In this regard, our work compared to [16] goes one step beyond having data processing. The authors in [17] and [18] have used machine learning techniques to obtain smart farming. In these works, the Satcom system used is for LEO satellites. Also, they do not integrate with the core network as we propose. On the other hand, the authors in [19] present the lines of research in 5G, and IoT integration applied to Smart farms, but not considering the Satcom nor HAPS.

Regarding AWS, the authors in [20] propose an IoT-based system using AWS to monitor the water. This system can be used for Smart Rural. However, there is no transmission system (for example, a Satcom system) to send data to the core network to process.

Routing data packets from source to destination to process them is a challenge in IoT networks. For example, latency is significant for urgent data, which is crucial when we include satellite links. In [21], the authors propose an efficient message passing in IoT networks based on network softwarization, wherein the logical control plane

is decoupled from the data plane of hardware devices such as routers and switches. However, they focus only on IoT applications. Extending this application to satellite links or with HAPS is an open issue.

In the field of research, there are two projects to integrate the satellite with 5G networks that were discussed in the introduction:

- SaT5G: Research, develop and validate key technology enablers through live 5G testbeds demonstrations as a European initiative. This proposal delivers services for a ubiquitous end-user of at least 50 Mbps 5G broadband in Media & Entertainment, Transportation, Health, Logistics and Agriculture Industries in developed and emerging markets [11].
- SATis5G: is a European Space Agency (ESA) project to build a large-scale real-time live end-to-end 5G integrated satellite-terrestrial network proof-of-concept testbed. The demonstrator implements, deploy and evaluates an integrated satellite-terrestrial 5G network, showcasing the benefits of the satellite integration with the terrestrial infrastructures as part of a comprehensive communication system. [12].

On the one hand, in previous projects, the satellite is the main element instead of considering HAPS as in this work. In addition, none of the projects is with IoT networks, nor do they talk about data processing.

We can see how different combinations between IoT, 5G, HAPS or satellites are not jointly proposed. For this reason, the objective of this work is to design a scheme that manages to integrate the three technologies, to improve rural smart systems.

3. Architecture Proposed

We propose an architecture composed of three segments of elements differentiated as shown in Figure 1: the *ground segment*, the *space segment* and the *Cloud segment*. These elements will communicate with each other to provide joint functionality to the system using emerging technologies such as cloud computing and the Internet of Things (IoT) supported by satellite communications.

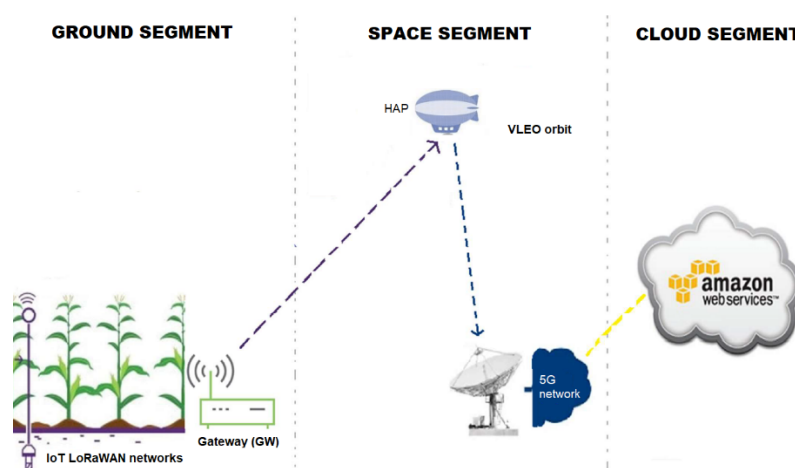

Figure 1. Architecture for a Communication System in Smart Rural.

3.1 Ground Segment Based on IoT

This first segment aims to define aspects of an IoT infrastructure that will gather the remote rural data by a Wireless Sensor Network (WSN) using a Low Power Wide Area Protocol (LPWAN), guaranteeing scalability and flexibility for new remote rural areas that could be incorporated into the system at any time. A summary of protocols available in the current state of the art for these sensor networks in terms of bandwidth vs coverage comparison is shown in Figure 2. Long Range Wide Area Network (LoRaWAN), from LoRa Alliance [22], will be used among these protocols.

LoRaWAN employs a star topology, which is well-suited for IoT sensors' flexible and scalable deployment. Given that the smart agriculture system is not an ad hoc development but the implementation of a system that must be flexible and adaptable to the rural areas of potential clients, different sensors/nodes could be flexibly incorporated and deployed following this topology of the protocol. An essential element in the architecture of the LoRaWAN networks is the Gateway (GW) which has the mechanism of dynamic incorporation of child nodes according to Figure 3. Each LoRaWAN GW maintains a *child_list* of nodes/sensors attached to its network, initially empty at the network deployment in the rural area. In the initial stage, the GW broadcasts beacons periodically, allowing LoRaWAN nodes to join its network by sending a *JOIN* request (LoRaWAN standard

message) from them. Once the GW has the first child and child_list is not empty, it will stop transmitting the periodic beacon. Instead, the Gateway will be able to use packets sent to its children as beacons, notifying other nodes to join it if necessary. This Gateway is also responsible for communicating with the space segment of the Smart Rural system.

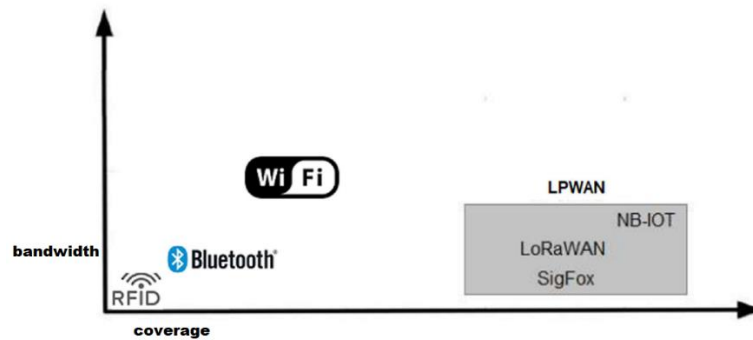

Figure 2. Bandwidth vs. Coverage of current LPWAN protocols.

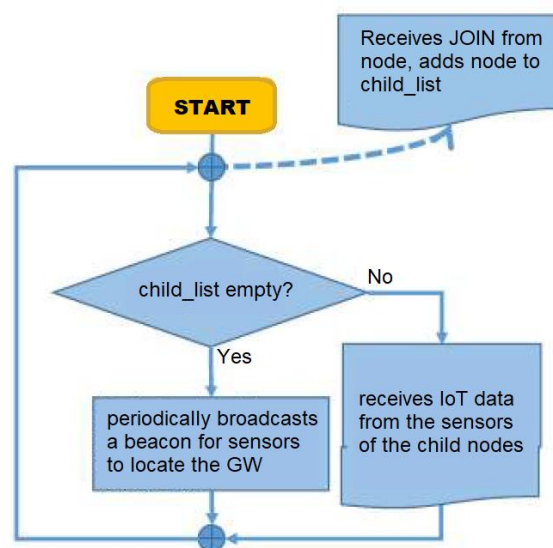

Figure 3. Flow of incorporation of new nodes to LoRaWAN Gateway

In the design of this segment, engineering issues should be considered:

- 1) **Hardware available to be used:** Standard and commercial solutions have been used both for the IoT sensors and for the Gateway [23], to ensure its integration into the scalable and flexible smart rural system. As for the IoT sensors, for each remote rural area or client of the system, different agricultural data measurements, such as soil moisture, luminosity or barometric pressure, can be taken with absolute flexibility. Therefore a list of commercial sensors selected for each type of measurement considered in the system is presented in Table 1. It is possible to obtain a specific type of measurement or combination for each rural area added to the system with the combined use of these sensors. The sensors listed in Table 1 do not have LoRaWAN connectivity and emission. Thus, to transmit the data from these IoT sensors to the corresponding gateway, the REYAX RYLR896 LoRa transceiver module (from Semtech) [22] will be used, combining this module with the sensor used in each case by means of an Arduino board. This transceiver reaches up to 15 Km of coverage. The hardware used in the system as Gateway for LoRa communication is Raspberry Pi 3 Model B+ in the 868 MHz frequency band (protocol standard for Europe). It must be taken into account that it is necessary to adjust the data to the transmission format of the customised protocol, which will be detailed below. For this objective, it is required to add to the signal transceiver module an element with programming capacity to give the necessary format to the IoT messages of the system.
- 2) **IoT-Space link communication protocol:** it is a customised communication protocol to transmit the IoT data from the rural area to the space segment. It is a custom-designed protocol to optimise and maintain a homogeneous and structured style which facilitates the subsequent processing and storage of this IoT data at the other end of the system (the cloud segment explained in Subsection 3.3).

Table 1. Hardware for IoT Sensors

Sensor	Measurement	Company	Reference
VH-400	soil humidity	Vegetronix	[24]
107-L temperature Sensor (BetaTherm 100K6A1B Thermistor)	soil temperature	Campbell Scientific	[25]
CM-100 compact weather station	atmospheric pressure	Stevens Water	[26]
XFAM-115KPASR	atmospheric pressure	Pewatron AG	[27]
BH1750	luminosity	Rohm	[28]

3.2 Space Segment Based on HAPS

This segment is responsible for connecting the ground segment to the cloud segment, acting as a bridge for IoT data from rural areas until end servers in a 5G terrestrial network. Satellite communications (Satcom) are the classical medium for providing global coverage from remote rural areas. Thanks to advances in nano-technologies, Satcom has garnered renewed interest in industry and research. Especially, miniaturisation and cost reduction in certain types of space vehicles allow the smart rural system to scale up by adding new remote rural areas with ease.

The lowest orbits will be considered for the smart rural system [29], since they are the ones that entail the lowest cost and the most straightforward space deployment. Our space segment is designed for Very Low Earth Orbit (VLEO), over an altitude of about 20 km, which offers the following benefits:

- Low altitude compatibility with the LoRaWAN distance restriction of the range of the transceiver module of a terrestrial GW -The same Semtech's REYAX RYLR896 LoRa transceiver [22], mentioned in the elements of both parts of the system (terrestrial gateway/s and space systems) will be used.
- Significant reduction in size, power consumption, mass, and therefore cost of deployable space vehicles in this type of orbit.
- Lower attenuation (path-loss) of the power density of the electromagnetic signal and lower emission power required at the terrestrial LoRaWAN GW, with the corresponding energy savings that this entails. Since the power density of a signal is proportional to the inverse square of the distance from its origin: $P \propto 1/r^2$.
- Reduction of the impact of cosmic radiation, allowing the use of commercial off-the-shelf (COTS) electronic components.

High Altitude Platform (HAP) are considered to deploy this part of the system for ease of deployment in the agriculture sector [30]. Recent innovations such as thin-film solar cells [31], improvements in battery technology [32], advances in electric motors and super-thin helium envelope materials [33] have enabled the recent production of these systems at a reasonable development cost. Moreover, fit very well in the requirements of flexibility and scalability of the Smart Rural system as follows:

- **Geographic coverage:** HAPs provide an intermediate range of coverage, sufficient to allow coverage of many remote rural areas with a single HAP, the main limitation being the antenna technology. For a stationary HAP system of the Smart Rural system at the VLEO orbit altitude above 20 Km, there is a known and stable coverage area without handoffs. Therefore, it is only necessary to consider that the area of visibility of the HAP system covers the rural area and, at the same time, the terrestrial antenna of the final network to communicate the IoT data.
- **Reconfiguration:** a HAP system can operate for extended periods but can quickly be returned to the ground for reconfiguration or maintenance.

Through HAPS, IoT data will reach by routing cloud servers within a 5G core network to storage and processing. 3GPP considers the satellite a member of future terrestrial networks from Release 15 [10]. Particularly, the latest lines of work and research from organisations such as GSMA also speak of the future relevance of the integration of HAPs as another component of 5G networks [34]. This proposal selects two types of HAP vehicles whose features are collected in Table 2.

Table 2. Types of Hap Vehicles

	Airships	Aircrafts
Size	length 150-200 m	wingspan 35-70 m
Power supply	solar panels (+fuel)	solar panels (+fuel)
Flight duration	up to 5 years	about 6 months
Stationary position	Yes. Variations of 1 cubic kilometre	Yes. Variations of 1-3 kilometers

Two aspects must be detailed in the design of the space segment:

- 1) **HAPs dimensioning:** the terrestrial coverage offered by a HAP system is represented in Figure 4 and mathematically expressed in terms of the maximum line of sight radius (line of sight, LOS) as follows

$$R + h / \sin(90 + \alpha) = R / \sin(\beta) \quad (1)$$

Where h is the HAP altitude, R is the radius of curvature of the earth (we assume a radius of 6400 Km), α represents the elevation angle on the ground, and β is the angle of view of the HAP system. On the other hand, the distance between A and B in Figure 4 is obtained as follows

$$r = AB = \left[\cos^{-1} \left((R / R + h) \cos \alpha \right) - \alpha \right] * 2R \quad (2)$$

This procedure is applied for a HAP system stationed in orbit above the 20 Km altitude set for the smart rural system resulting in a circular coverage area of about 120 Km radius as shown in Figure 5. Thus, a single HAP system provides extensive coverage of a circular area of about 45000 Km^2 $\left[(\pi * 120 \text{ Km}^2) \right]$, allowing the incorporation of the smart rural system of a large number of data from different rural areas within this area. In addition to this coverage area, for the same deployed HAP system, an addressable antenna/transceiver or Mul-tiple Inputs-Multiple Outputs (MIMO) antenna could be considered so that other coverage cells (elliptical) would be added without the need to deploy more HAP platforms, this is represented in Figure 6.

- 2) **Space-Ground communication link:** It is a protocol to communicate this space segment with 5G terrestrial networks. In this line, the proposed system takes advantage of the versatility of the New Radio (NR) defined in 5G technology. The 5G architecture is, in fact, based on this overall flexibility and the ability to reprogram for dynamic adoption and cohesion of different services, regardless of the underlying physical architecture (Network Function Virtualization -NFV- and Software Defined Networks -SDN-).

In this downlink of the HAP systems of the smart rural system with the 5G terrestrial networks for IoT data communication, the 2.1 GHz frequency band will be used, which is currently regulated by the ITU (International Telecommunication Union) for systems operating at the altitude of HAPs. Moreover, the transmission rate of this link at the indicated frequency would be about 50-60 Mbps [34], a value more than adequate for the transmission of IoT messages from rural areas.

For this 5G radio access network (5G NR) that the HAP platform/s of the system will use, an Orthogonal Frequency Division Multiplexing (OFDM) access is defined in the 5G standard, where the 2.1 GHz frequency channel bandwidth is divided into multiple subcarriers of different frequencies orthogonal to each other, each of these subcarriers transporting information modulated in either Quadrature Amplitude Modulation (QAM) or Phase Shift Keying (PSK) frequency. This way, the data signals of the different potential customers incorporated in the smart rural system would be transmitted on different subcarriers, thus bringing the data to a 5G core network, where they can be routed to the cloud segment.

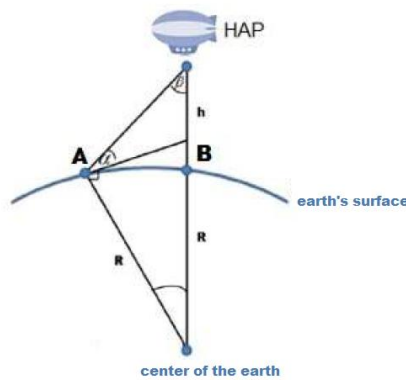

Figure 4. HAP coverage calculation parameters.

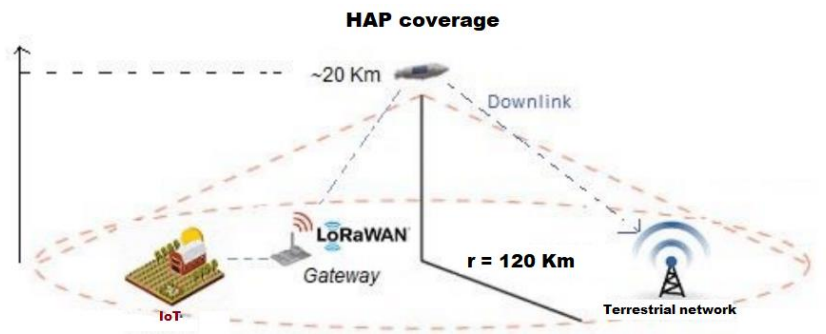

Figure 5. HAP coverage at 20 km altitude

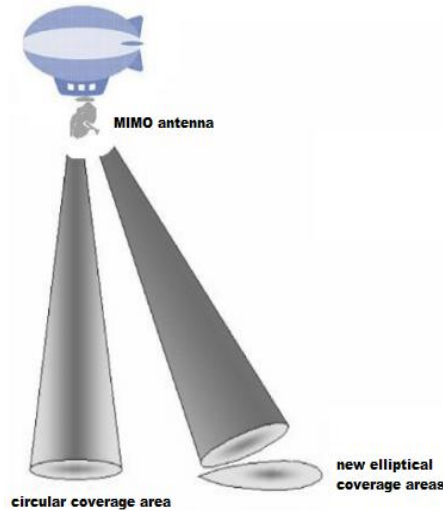

Figure 6. Increased HAP coverage with MIMO

The space segment is composed of the HAPS. This segment has been simulated with MATLAB using the channel models exposed in [35]. Through an interface, MATLAB has been connected to the AWS services deployed. The data captured by the sensors are passed to MATLAB to simulate the passage through the HAP, including the losses that the link space would include. We simulate rain and other atmospheric effects characteristic of space links based on the channel model explained in [35] for NGSO systems and HAPs. Then the data, once the link losses are added, is passed through MATLAB to AWS for final processing.

3.3 Cloud Segment Based on AWS

This segment is responsible for processing and warehousing the IoT data using Amazon cloud services; Amazon Web Services (AWS). The data is routed from the corresponding terrestrial network, a 5G network core, as shown in Figure 7.

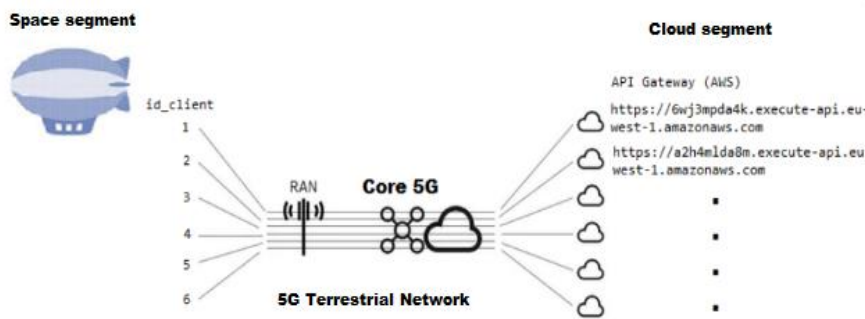

Figure 7. Network Slicing in 5G, IoT data routing to AWS.

The requests with the data messages will be routed to the endpoint of the Application Programming Interface (API) deployed for remote access in the AWS cloud architecture of the account created for the corresponding client. A routing table of the possible client IDs of the messages (*id_client*) with the endpoint/s of the APIs

deployed in AWS cloud services will be used. This routing could be done with independent subnets to ensure each client's security and data isolation, using one of the main features of 5G technology, Network Slicing.

The design of the AWS cloud architecture for the system is based on Event-Driven principles [36]. In this regard, the architecture facilitates the organisation, scalability and subsequent pricing to the client, with the capacity to incorporate new clients or rural areas into the smart system, with high availability and accessibility of the data from anywhere through the Internet.

A high-level overview of managing clients and rural areas with the AWS cloud architecture is shown in Figure 8.

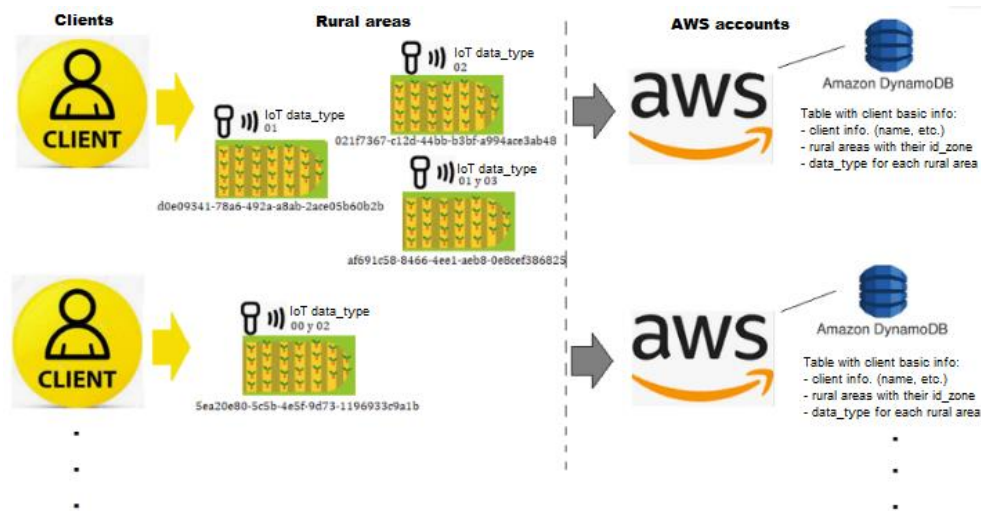

Figure 8. Client and rural areas management scheme in the cloud.

Then, an AWS account is created for each client that joins the smart rural system. Thus, all the services deployed for storing each client's data will be deployed in their particular AWS account.

Since each client could incorporate different rural areas into the system, with different types of data generated by the sensors installed Table 1, this basic information will be recorded in a DynamoDB table. There will be one, therefore, in all the accounts of each client, with this corresponding basic information.

On this basis, the cloud system architecture detailed below will be deployed for each client. This architecture is shown in Figure 9. To facilitate this process of replication and deployment of the cloud infrastructure between AWS clients' accounts, automation scripts have been developed using Boto3 and Python as the programming language. All IoT messages will be processed and stored with high availability in DynamoDB tables, ready for data analysis processes and visualization over the Internet from anywhere in the world.

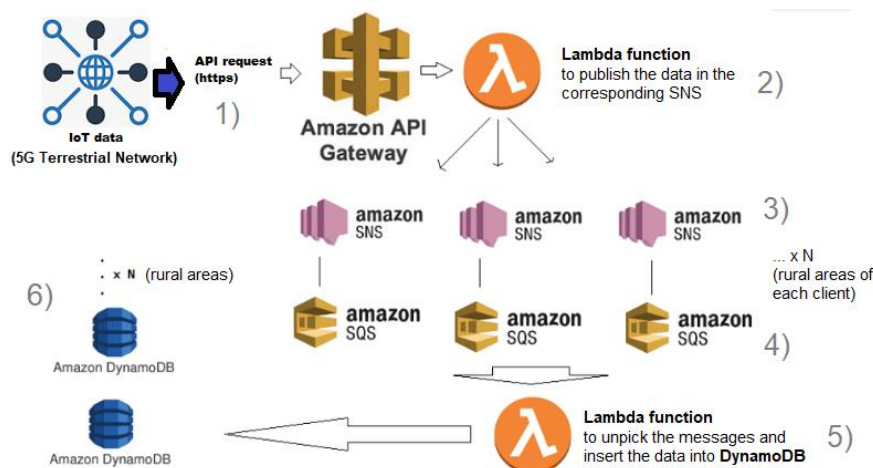

Figure 9. AWS architecture of the smart rural system.

The components of AWS are shown in Figure 9, where we have

- 1) **Receiving IoT messages:** Each IoT data_type from a sensor is received in a request to the REST API (standard HTTP -Hypertext Transfer Protocol-), deployed and exposed through the Amazon API Gateway

service, which allows APIs to be deployed quickly and with high performance, up to 10,000 requests in one second in a uniform manner [13].

- 2) **Preprocessing of IoT messages:** Each request is automatically processed by AWS, invoking a Lambda function. These functions have been programmed in Python language. At this point, these functions aim to publish the IoT data from the request message to the corresponding Amazon SNS. To find out which Amazon SNS to direct the message to, the function examines the rural zone identifier field (*id_zone*), given that the client has one SNS deployed in its AWS account for each contracted rural zone.
- 3) **Publication of messages in SNS:** After these lambdas, the messages are published in the Amazon SNS service, a publish/subscribe messaging service designed for notifications or events in distributed systems, which due to its high-performance characteristics, is very appropriate for processing a multitude of data messages.
- 4) **Queuing of messages in SQS queues:** Each of these Amazon SNSs will have a queue subscribed to the Amazon SQS service so that AWS automatically and fully manages all messages published in an SNS to the corresponding SQS queue. This queue-based management of IoT data messages enables the smart rural system to process the message load in an appropriate, scalable and data-lossless way.
- 5) **Dequeue and processing of IoT messages:** In turn, each of these SQS queues has a new Lambda function subscribed to it. The purpose of this function is to process and insert the IoT data message into the corresponding DynamoDB table according to the identifier field of the rural area from which the data originates (*id_zone*) and to enqueue/remove the message from the queue after successful insertion. AWS is responsible for managing and autonomously invoking the function so that it processes blocks of messages of the number indicated each time there is a sufficient number of messages in the SQS queue. AWS automatically removes the messages from the queue after successfully executing the Lambda.
- 6) **IoT data storage:** The final point of the system is storing the data in DynamoDB tables, remembering that there is a data table for each client's rural area. DynamoDB is a NoSQL key-value database, therefore perfect for the IoT data of the system. Moreover, it is fully managed by AWS and designed to run high-performance applications, so it will allow storing IoT data from rural areas of the smart rural system without any issues.

The flow that IoT data messages will follow through the cloud infrastructure until they are stored is summarised in Figure 10.

Messages are routed from the terrestrial network to the API Gateway as an entry point to the cloud. They are published in an SNS service topic via AWS Lambdas, to which the corresponding SQS queue is subscribed. This queuing without data loss allows messages to be processed in blocks by other AWS Lambdas responsible for final processing and storing the IoT data in the corresponding DynamoDB table.

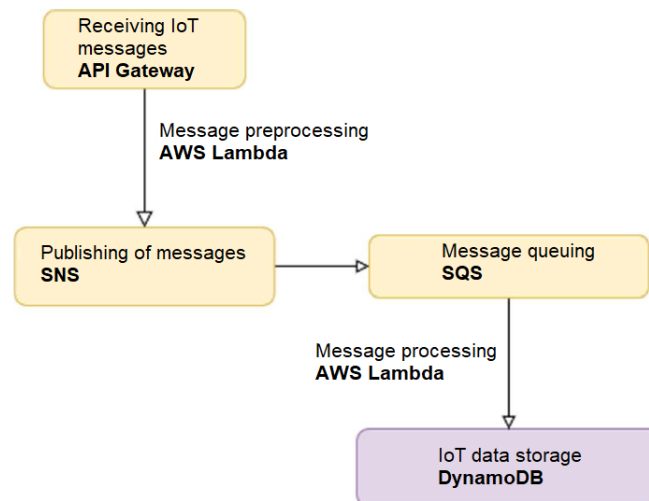

Figure 10. Message flow in the AWS segment.

4. Communication Protocol

The communication between the sensors in the rural part and the HAPS requires a protocol tailored to the data in each case of agriculture. This protocol must bring together the information from all the sensors and send it to HAPS in the space segment as explained in Subsection 3.2. It will provide a homogeneous and structured

format for all messages in the system, thus facilitating the subsequent processing and storage of the IoT data at the end of the cloud services.

The proposed protocol is based on the JSON key-value standard [37], which is the de facto standard for communication in many data-driven systems, like IoT sensors and data warehouses. Therefore, the messages of the smart rural system will use JSON-structured files with the following keys:

- **Id_client.** An integer ≥ 1 to identify the client of data origin.
- **Id_zone.** An alphanumeric string of 36 characters is to identify the client’s rural zone since it should be remembered that a client can have different rural zones to be analysed in the smart rural system. This alphanumeric string will therefore be an alphanumeric UUID (Universally Unique Identifier) of type 4, according to the standard defined in RFC 4122 [38].
- **data_type.** According to the sensor measurement, a numeric prefix string is shown in Table 1. The identifiers given to the different types of measurements for the IoT messages are those in Table 3:
- **data.** The numeric value of the measurement taken by the corresponding sensor.
- **timestamp.** Timestamp for the data in UTC (Coordinated Universal Time), standard format with micro time accuracy: yyyy-mm-ddThh:mm:ss.sssZ.

Table 3. Identifiers for Agricultural Measurements

Agricultural measurement	Id
soil temperature	00
soil moisture	01
luminosity	02
atmospheric pressure	03

An instance of a system message according to this protocol would be as follows

```
{
  "id_client": 2,
  "id_zone": "bd65600d-8669-4903-8a14-af88203add38",
  "data_type": "01",
  "data": 0.346437,
  "timestamp": "2021-12-24T14:25:25.542Z".
}
```

This scheme ensures the scalability and flexibility of the system to incorporate new clients, rural areas or rural measurements while maintaining the same key-value standard structure.

The structured file corresponding to IoT messages from sensors will be inserted into the data field “payload” of each LoRaWAN standard message.

5. Simulations and Results

As a result of the design of the three exposed segments, a flexible and fully scalable smart rural system is achieved, which allows for progressively incorporating IoT data from different rural areas and with different types of data for the same client, or new clients with new rural areas to be implemented.

The coverage area of the deployed HAP platform of 45000 Km^2 allows it to cover almost half of the province of Castilla y Leon, a community in Spain with many rural areas and vital wine farms. In this sense, measurements taken in the Smart Rural system, such as soil temperature, are used to know the grape ripening stage. This area also has the 5G antenna for routing data to Cloud services.

The data is held on highly available systems in the AWS cloud, made available from a single point of access - Single Sign-ON (SSO) - in the AWS console, the accounts of all the clients incorporated into the system, with access to their IoT data and cloud infrastructure. This SSO console access is shown in Figure 11.

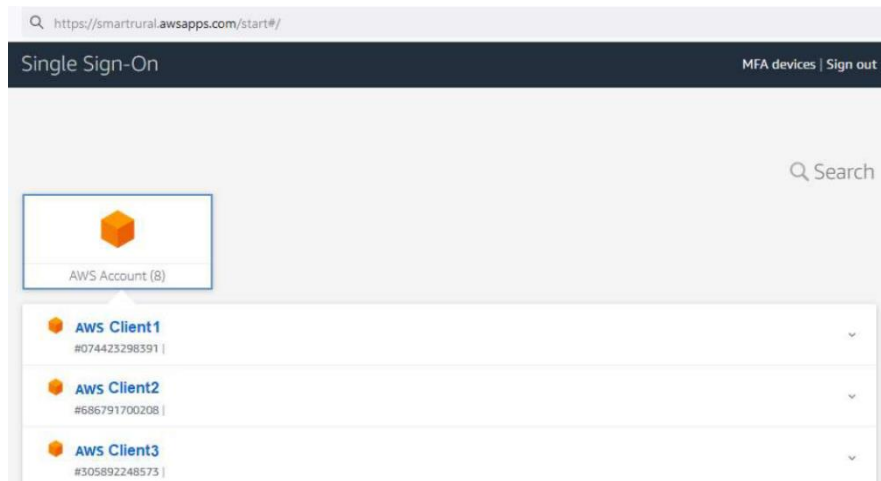

Figure 11. AWS Management Console, access with SSO

The cloud-distributed architecture design automatically scales with the flow of IoT data through AWS self-management of all services used, such as AWS Lambdas that are invoked and managed concurrently, API Gateway, SNS, and SQS adjust to the number of messages they receive, and DynamoDB. Their tables are deployed with the Python scripts in the on-demand mode that adapt to the flow of reads and writes required at any given time.

The developed scripts with the configuration in Table 4 automatically deploy the different systems of the Cloud architecture.

Table 4. Simulation Configuration in Cloud

System	Param	Value
AWS Lambda	Language	Python 3.8
AWS Lambda	Architecture	x86 64
AWS Lambda	Memory	128 MB
AWS Lambda	Timeout	60 s
SNS	Type	Standard
SQS	Type	Standard
SQS	Visibility timeout	360 s (6*Lambda timeout)
SQS	Retention period	1 day
SQS	Delay	0 s
SQS	Max msg size	256 KB
SQS	Encrypt	SSE-SQS
DynamoDB	Read capacity	On-demand
DynamoDB	Write capacity	On-demand

The metrics that the AWS console provides with services such as CloudWatch make it possible to observe the excellent performance of the cloud segment of the smart rural system. For example, in the invocations of the Lambda finally responsible for inserting IoT data into DynamoDB (step 5 in Figure 9), concurrent requests for more than 400 messages with an average duration of milliseconds in each processing and without errors. The metrics represented by the own AWS console are shown in Figure 12. For the visualization of Figure 12 in the AWS console interface, an observation period of several hours (9 to 11 AM) is considered, as it is read on the axis of the graph, for which it is shown: In the left graph, the number of concurrent invocations in absolute terms, which allows seeing, the flow of IoT messages being processed and inserted into the tables in a concurrent way. The middle graph shows the running times of these AWS Lambda processes, showing the maximum, minimum and average times of decollating and data insertion. Where the good behavior of the system is observed, given that they are located in terms of milliseconds. The graph on the right shows the error rate in these AWS Lambda executions for data processing, where it can be seen that there has been no error and all concurrent invocations have ended successfully. In any case, if an error occurs and the execution of the AWS Lambda fails, the data would not be lost thanks to the proposed architecture since the AWS itself would be responsible for requesting the message in the SQS queue.

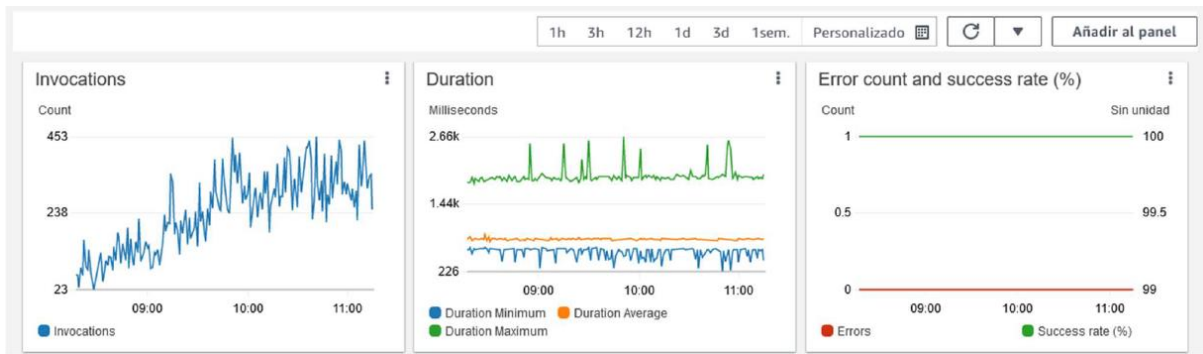

Figure 12. Smart rural system performance at final Lambda

Also, in the AWS console interface for each DynamoDB table, as shown in Figure 13, the IoT data stored in each rural area, with its partition key (`data_type` indicating the agricultural measurement) and its sort key (`timestamp`), can be observed; these items of each table, with the measured values of soil moisture and luminosity, can be queried and viewed directly from the AWS interface.

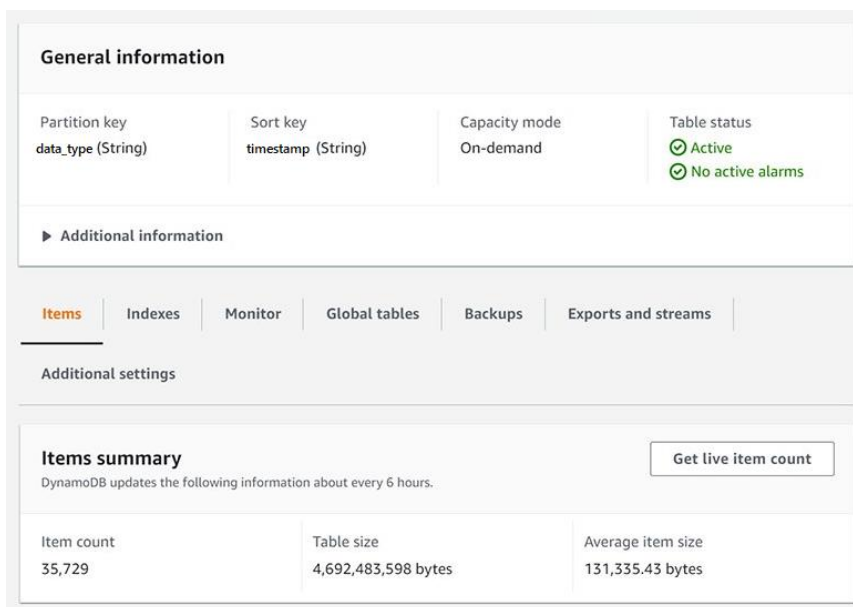

Figure 13. AWS interface for a DynamoDB table of data

6. Conclusion

In this work, we have proposed an architecture based on emerging technologies such as IoT and AWS to make rural environments smart to improve the quality of agricultural systems. The solution is composed of three segments. In addition, new space communications and HAPS have been used to transmit data from remote rural areas to the core of the 5G network. The proposed architecture allows the integration, collection and processing of agricultural data such as soil moisture. This data is processed in AWS and stored.

In addition, a tailored protocol has been designed to transmit and process the messages of IoT data so that the fields that the message will consist of are predefined and known in advance, which will influence the programming of the scripts of AWS cloud architecture.

Conflict of Interest

There is no conflict of interest for this study.

References

- [1] Ahmed, S.H.; Guizani, M.; Lloret, J.; Rawat, D.B.; Guibene, W.; Zhong, Z. Imminent communication technologies for smart communities: Part 2. *IEEE Commun. Mag.* **2018**, *56*, 80–81, <https://doi.org/10.1109/MCOM.2018.8419183>.
- [2] Baumüller, H. Towards smart farming? Mobile technology trends and their potential for developing country agriculture. *Handbook on ICT in Developing Countries*. River Publishers: Aalborg, Denmark, 2017; pp. 191–210.
- [3] Smart-Akis: European Agricultural Knowledge and Innovation Systems (AKIS). Available online: <https://www.smart-akis.com/> (accessed on 31 May 2022).
- [4] Demeter - Empowering Farmers. Available online: <https://h2020-demeter.eu/> (accessed on 30 May 2022).
- [5] Kaur, K. A survey on internet of things – architecture, applications, and future trends. In Proceedings of 2018 First International Conference on Secure Cyber Computing and Communication (ICSCCC), Jalandhar, India, 15–17 December 2018. <https://doi.org/10.1109/ICSCCC.2018.8703341>.
- [6] Abbasi, M.; Yaghmaee, M.H.; Rahnama, F. Internet of things in agriculture: A survey. In Proceedings of 2019 3rd International Conference on Internet of Things and Applications (IoT), Isfahan, Iran, 17–18 April 2019. <https://doi.org/10.1109/IICITA.2019.8808839>.
- [7] Osoro, O.B.; Oughton, E.J. A Techno-Economic Framework for Satellite Networks Applied to Low Earth Orbit Constellations: Assessing Starlink, OneWeb and Kuiper. *IEEE Access* **2021**, *9*, 141611–141625, <https://doi.org/10.1109/access.2021.3119634>.
- [8] Saeed, N.; Elzanaty, A.; Almorad, H.; Dahrouj, H.; Al-Naffouri, T.Y.; Alouini, M.-S. CubeSat Communications: Recent Advances and Future Challenges. *IEEE Commun. Surv. Tutorials* **2020**, *22*, 1839–1862, <https://doi.org/10.1109/comst.2020.2990499>.
- [9] Kurt, G.K.; Khoshkholgh, M.G.; Alfattani, S.; Ibrahim, A.; Darwish, T.S.J.; Alam, S.; Yanikomeroğlu, H.; Yongacoglu, A. A Vision and Framework for the High Altitude Platform Station (HAPS) Networks of the Future. *IEEE Commun. Surv. Tutorials* **2021**, *23*, 729–779, <https://doi.org/10.1109/comst.2021.3066905>.
- [10] G. T. 38.811, 3GPP. Study on New Radio (NR) to support non-terrestrial networks. Available online: <https://portal.3gpp.org/desktopmodules/Specifications/SpecificationDetails.aspx?specificationId=3234> (accessed on 1 Jun 2022).
- [11] SaT5G Project. Available online: <https://www.sat5g-project.eu/> (accessed on 30 May 2022).
- [12] SATis5. Demonstrator for Satellite-Terrestrial Integration in the 5G Context. Available online: <https://satis5.eurescom.eu/> (accessed on 31 May 2022).
- [13] AWS. Available online: <https://docs.aws.amazon.com/eses/apigateway/latest/developerguide/http-apithrottling.html> (accessed on 29 September 2022).
- [14] Kumhar, M.; Bhatia, J. Emerging Communication Technologies for 5G-Enabled Internet of Things Applications. **2020**, 133–158, https://doi.org/10.1007/978-3-030-67490-8_6.
- [15] Monzon Baeza, V.; Ortiz, F.; Herrero Garcia, S.; Lagunas, E. Enhanced Communications on Satellite-Based IoT Systems to Support Maritime Transportation Services. *Sensors* **2022**, *22*, 6450. <https://doi.org/10.3390/s22176450>.
- [16] Nawandar, N.K.; Satpute, V. IoT based intelligent irrigation support system for smart farming applications. *Adv. Distrib. Comput. Artif. Intell. J.* **2019**, *8*, <https://doi.org/10.14201/ADCAIJ2019827585>.
- [17] Dahane, A.; Benameur, R.; Kechar, B.; Benyamina, A. An IoT Based Smart Farming System Using Machine Learning. In Proceedings of 2020 International Symposium on Networks, Computers and Communications (ISNCC), Montreal, QC, Canada, 20–22 October 2020. <https://doi.org/10.1109/isncc49221.2020.9297341>.
- [18] Dhedia, R.; Paliakkara, N.; Lobo, V.B.; Gupta, D.; Sharma, V. Smart agri-farming on satellite imageries using machine learning. In Proceedings of 2021 6th International Conference on Communication and Electronics Systems (ICES), Coimbatre, India, 8–10 July 2021. <https://doi.org/10.1109/ICES51350.2021.9489130>.
- [19] Zhang, J.; Zhang, R.; Yang, Q.; Hu, T.; Guo, K.; Hong, T. Research on Application Technology of 5G Internet of Things and Big Data in Dairy Farm. In Proceedings of 2021 International Wireless Communications and Mobile Computing (IWCMC), Harbin, China, 28 June–2 July 2021, <https://doi.org/10.1109/iwcmc51323.2021.9498643>.

- [20] Kodali, R.K.; Sabu, A.C. Aqua monitoring system using AWS. In Proceedings of 2022 International Conference on Computer Communication and Informatics (ICCCI), Coimbatore, India, 25–27 January 2022. <https://doi.org/10.1109/ICCCI54379.2022.9740798>.
- [21] Jadav, N.K.; Nair, A.R.; Gupta, R.; Tanwar, S.; Lakys, Y.; Sharma, R. AI-driven network softwarization scheme for efficient message ex-change in iot environment beyond 5g. *Int. J. Commun. Syst.* **2022**, e5336, <https://doi.org/10.1002/dac.5336>.
- [22] Park, S.K.; Hwang, K.I.; Kim, H.S.; Shim, B.S. Challenges and experiment with LoRaWAN. *Advanced Multimedia and Ubiquitous Engineering*. Springer: Singapore, 2017; pp. 269–276.
- [23] Fernandez, L.; Ruiz-De-Azua, J.A.; Calveras, A.; Camps, A. Assessing LoRa for satellite-to-earth communications considering the impact of ionospheric scintillation. *IEEE Access*, **2020**, *8*, 165570–165582, <https://doi.org/10.1109/ACCESS.2020.3022433>.
- [24] VH400. Vegetronix. Available online: <https://satis5.eurescom.eu/> (accessed on 31 May 2022).
- [25] 107-L temperatura sensor. Campbell Scientific. Available online: <https://www.campbellsci.es/107> (accessed on 31 May 2022).
- [26] CM-100 datasheet. Overtechsolucoes, Stevens Water. Available online: <https://www.overtechsolucoes.com.br/storage/datasheets/cm-100datasheet.pdf> (accessed on 31 May 2022).
- [27] XFAM-115KPASR datasheet. Available online: <https://pdf1.alldatasheet.com/datasheet-pdf/view/203341/FUJIKURA/XFAM-115KPASR.html> (accessed on 31 May 2022).
- [28] BH1750. Rohm. Available online: <https://www.mouser.es/datasheet/2/348/Rohm11162017 ROHMS34826-1-1279292.pdf> (accessed on 31 May 2022).
- [29] Millan, R.M.; von Steiger, R.; Ariel, M.; Bartalev, S.; Borgeaud, M.; Campagnola, S.; Castillo-Rogez, J.C.; Fléron, R.; Gass, V.; Gregorio, A.; et al. Small satellites for space science: A COSPAR scientific roadmap. *Adv. Space Res.* **2019**, *64*, 1466–1517, <https://doi.org/10.1016/j.asr.2019.07.035>.
- [30] Arum, S.C.; Grace, D.; Mitchell, P.D. A review of wireless communication using high-altitude platforms for extended coverage and capacity. *Comput. Commun.* **2020**, *157*, 232–256, <https://doi.org/10.1016/j.comcom.2020.04.020>.
- [31] Efaz, E.T.; Rhaman, M.; Al Imam, S.; Bashar, K.L.; Kabir, F.; Mourtaza, E.; Sakib, S.N.; Mozahid, F.A. A review of primary technologies of thin-film solar cells. *Eng. Res. Express* **2021**, *3*, 032001, <https://doi.org/10.1088/2631-8695/ac2353>.
- [32] Pruthvija, B.; Lakshmi, K.P. Review on Battery Technology and its Challenges. *Int. J. Sci. Eng. Res.* **2020**, *11*, 1706–1713.
- [33] Vasudevan, D.; Mohan, H.; Gaggar, S.; Gupta, R.B. Analysis and retardation of helium permeation for high altitude airship envelope material. **2019**, *2148*, 030027, <https://doi.org/10.1063/1.5123949>.
- [34] High Altitude Platform Systems, Towers in the Skies. Available online: <https://www.gsma.com/futurenetworks/wpcontent/uploads/2021/06/GSMA-HAPS-Towers-in-the-skies-Whitepaper-2021-1.pdf> (accessed on 31 April 2021).
- [35] Monzon Baeza, V.; Lagunas, E.; Al-Hraishawi, H.; Chatzinotas, S. An Overview of Channel Models for NGSO Satellites. arXiv preprint, arXiv:2209.10173, <https://doi.org/10.48550/arXiv.2209.10173>.
- [36] Pogiatzis, A.; Samakovitis, G. An Event-Driven Serverless ETL Pipeline on AWS. *Appl. Sci.* **2020**, *11*, 191, <https://doi.org/10.3390/app11010191>.
- [37] RFC 7158. Internet Engineering Task Force. Available online: <https://www.rfc-editor.org/rfc/rfc7158> (accessed on 29 September 2021).
- [38] RFC 4122. Network Working Group. Available online: <https://www.rfceditor.org/rfc/rfc4122> (accessed on 29 September 2021).