

## Optimal Design of Cap Screw Thread Runout for Transversal and Axial Loads

Kedziora S\*

Faculty of Science, Technology and Communication, University of Luxembourg, Campus Kirchberg, 6 rue Coudenhove-Kalergi, L-1359 Luxembourg, Luxembourg

### Abstract

The presented work is focused on a design of a new thread runout of screws and bolts subjected by transversal loads. These types of loads can occur in a normal service of bolt connection and they can lead to a failure. Two failure modes of the screw could occur: self-loosening of the screw or fatigue failure of the screw. The latter failure mode is analysed in the presented project focusing on an improvement of the existing design of the screws in terms of fatigue failure. The fatigue fracture of the screws, which are loaded by the transversal load, occurs normally in a groove of a first thread run of an engagement. A shape of the thread runout has some influence on stress in the thread therefore that shape can optimize to minimize the thread stress. Considering this, free shape optimisation was employed to find the best runout shape. As results of the presented work, the optimum design of the thread runout is proposed for the analysed conditions. The elaborated design of the cap screw brings significant improvement of the lifetime when the cycling tangential load occurs. In addition, the new design gives the better structural performance than the existing designs also for the cycling normal loads.

**Keywords:** Finite element method; Structural optimisation; Fatigue; Screws; Bolts; Thread runout

### Introduction

There is a difference between the bolt and the screw. A bolt is a threaded fastener mated with a nut, but a screw has either pre-formed or self-made internal threads. The presented work concerns the cap screw only (Figure 2).

Bolts and screws are the most popular fasteners utilized for machine designs, their characteristic features are a simply design, easy disassembly process and standard designs. Obviously, they have also drawbacks, as they are expensive in production, have complex assembly process, and are sensitive to fatigue fracture due to manufacturing and assembly errors.

Taking into account fatigue strength, most critical part of bolts/screws is the threaded part of the bolt, precisely a first groove of a first turn in an engagement [1] (Figure 1). The very high stresses are present there, because the thread generates the stress concentration and the first run of the thread transfers the most load about 34% of the total load.

Those stresses can be reduced assuming the same geometry of the thread using three methods, namely:

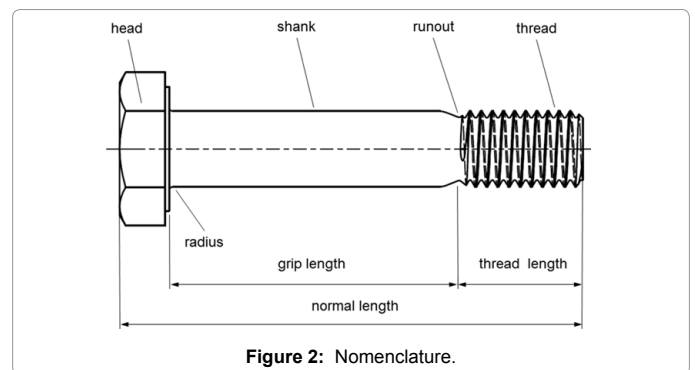

Figure 2: Nomenclature.

- Reducing an amplitude of external load by a change for instance a pattern of screws
- Reducing an amplitude screw load by using reducing bolt/screw stiffness and increasing member stiffness
- Changing a runout of the screw thread employing structural optimisation.

In this work, the latter method was investigated focusing on reduction of the thread stress. It should be mentioned here that a connection between a shank and a head is a sensitive region where failure can occur, but normally this problem can be solved by increasing a radius between those features.

For a standard connection, the bolts are used to achieve a very high

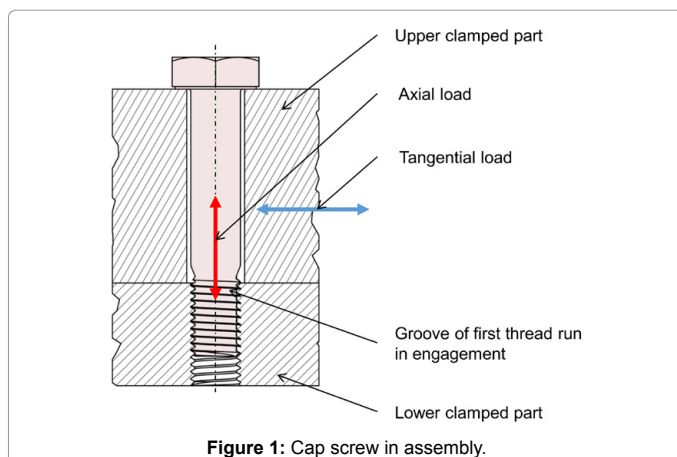

Figure 1: Cap screw in assembly.

\*Corresponding author: Kedziora S, Faculty of Science, Technology and Communication, University of Luxembourg, Campus Kirchberg, 6 rue Coudenhove-Kalergi, L-1359 Luxembourg, Luxembourg, Tel: +352 46 66 44 1; E-mail: [slawomir.kedziora@uni.lu](mailto:slawomir.kedziora@uni.lu)

Received January 13, 2017; Accepted February 04, 2017; Published February 08, 2017

Citation: Kedziora S (2017) Optimal Design of Cap Screw Thread Runout for Transversal and Axial Loads. J Appl Mech Eng 6: 250. doi: [10.4172/2168-9873.1000250](https://doi.org/10.4172/2168-9873.1000250)

Copyright: © 2017 Kedziora S. This is an open-access article distributed under the terms of the Creative Commons Attribution License, which permits unrestricted use, distribution, and reproduction in any medium, provided the original author and source are credited.

preload to clamp members in order to transfer the loads through friction forces between the members themselves and between the members and a bolt head and a nut. Therefore, theoretically, tangential loads do not load those bolts, only an axial load is present. The axial load in the bolts depends on stiffness of the bolt and the stiffness of the members. Unfortunately, this is theoretical assumption; in real applications, the tangential loads could also load the bolt due to existing manufacturing defaults - for instance clearances between parts and overloading (Figure 3).

In case of variable axial loads, the bolts/screws can withstand maximum alternating stress in range of 50 – 70 MPa [1]. The bolt preload, which is slightly lower than a yield strength of the bolt material, determines that limitation.

For fitted bolts/screws, the tangential loads are transferred by bolt shearing due to a fit connection between the bolt shank and a bolthole of the member. By means of this method, the great tangential load can be transferred without any problems. There is one issue with that solution - a cost, which is higher than for the standard bolts because of a required tolerance fitting between components and assembly time. Therefore, they are utilized only when they are certainly needed for example to transfer very high cycling tangential load.

As it was stated, the tangent loads can occur in case of the no-fitted bolts/screws for example in case when the load overcomes a maximum design load and slip in the connection occurs. For that

reason, the problem is important from a practical point of view. As it was commented, the standard bolt/screws are not designed for that type of the load. Hence, an idea of an improvement of the existing bolt/screw design arises so that to improve its fatigue resistance in the presence of small cycling tangential loads. Taking into consideration this aspect, an objective of the work is to find the optimum design of a thread runout so that to reduce the stresses in the bolt/screw thread loaded with the preload and the cycling transversal loads. It was assumed that the existing solutions could be improved by using a structural optimisation method.

A standard ISO M12 × 1.75 mm class 10.9 – left handed threaded cap screw was analysed with the numerous designs of the thread runout; Figure 4 shows all analysed designs. Several existing solutions were analysed so that to have wide overview on stress/strain distributions in the screws and fatigue lifetime for defined loads.

Basing on the analysed existing designs a new design of the runout was elaborated and optimized. An optimum design for defined constrains and an objective was found by means of a commercial software Hypermesh 14.0. Specifically, free shape optimisation was utilised to obtain the optimum shape of the thread runout. The free shape optimisation method was developed by Altair Engineering Inc. [2], wherein the outer boundary of a structure is altered to meet with pre-defined objectives and constraints. The essential idea of free-shape optimization, where it differs from other shape optimization techniques, is that the allowable movement of the outer boundary is automatically determined, thus relieving users of the burden of defining shape perturbations. Explaining it in simple terms, the free shape optimisation depends on finite element modifications (not direct geometry modifications) in order to meet requirements in terms of the defined constrains and the objective function. The modification in the free size optimisation process of the elements cannot be too great, because it can lead to degeneration of the elements. Therefore, that type of the optimisation can be utilized only for a relatively small modification. The range of required geometrical changes into the project was small through a selection of a based design. Consequently, the selected optimisation method was successful.

The objective of the optimisation process was to minimize the maximum von Mises stress in the region of the maximum stress. This region was selected in the way that it covers a thread part where the maximum stress is located. The most loaded part of the correctly designed screw is the groove of the first thread run [1].

As noted, the variable tangential load can occur in different situation in mechanical applications of the bolts/screws and it leads to fatigue fracture or to self-loosening of a bolted connection [1]. The presented work is focused only on a failure mode due the fracture of the screws. The tangential load was defined by means of a displacement of 0.1 mm applied on the screw head. In addition, a normal load of 52.5 kN is defined as the pretension load – imposed during a tightening process of the screw and it was defined based on a recommendation of a standard [3].

A final comparison between the different designs was done employing two defined metrics:

- Lifetime of the screw in case of presence of the pre-load and the cycling tangential load
- Lifetime of the screw loaded with the pre-load and the cycle normal load.

A fatigue load was defined in the way that the tangential or axial

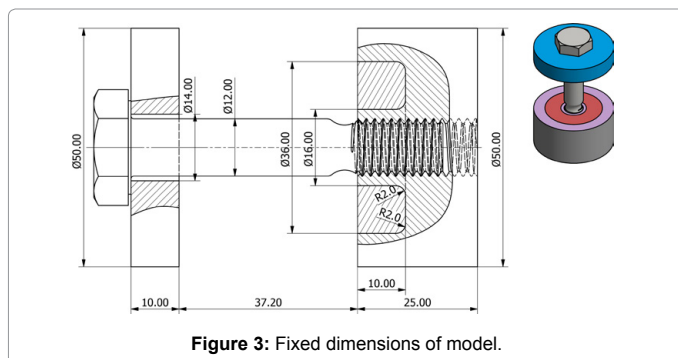

Figure 3: Fixed dimensions of model.

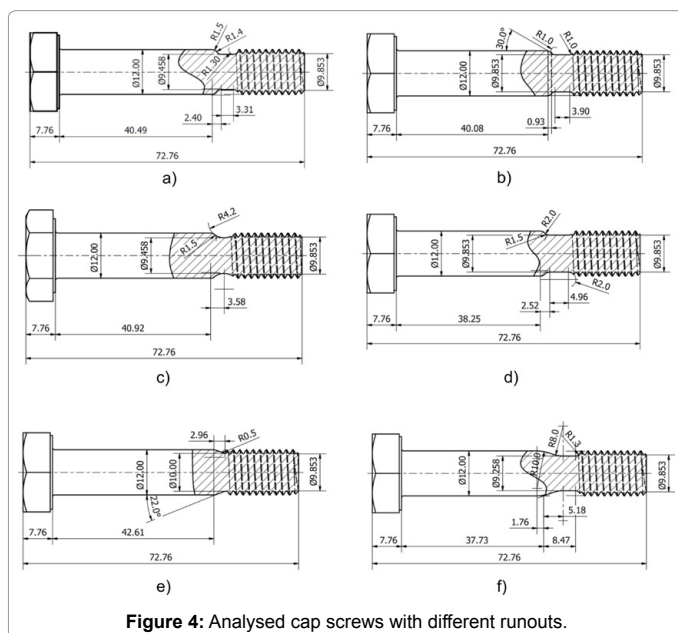

Figure 4: Analysed cap screws with different runouts.

loads are variable and the preload is constant. A run of the load was arbitrary defined and the fatigue analyses were conducted using a stain-life approach. Fatigue material properties were selected based on data from the book [4].

## Literature Review

Several authors worked on the similar problem and most of the time was focused on optimisation of the bolts for stress reduction in the thread in axial loads Pederson NL [5] and Govindu N [6]. In particular, the author [5] used parametric shape optimisation and a FE analysis for the whole bolt with the ISO thread. The solution of the shank-head (T-head) connection and for shank fillet shape for the thread was proposed for the tensile load only. The author achieved 34% reduction of the stress concentration factor in the thread and 25.3% for the T-head connection.

The authors [6] analysed stress distribution in Buttress and ACME bolts with different designs of the bolts and the nuts in order to show a quantitative comparison between Buttress and ACME bolts and to reduce a stress concentration factor in the thread. The authors showed that the Butter thread was better in terms of the stress concentration than the ACME bolts. The improve design was proposed with a step modification added to the nut with any grooves on the bolt or the nut. The analysed load in this case was a uniaxial tensile load applied in static load case. The problem was solved using finite element method.

The next interesting paper is Lee C-H [7] in which the authors showed an attempt to reduce a stress concentration in the thread by changing the shape of the nut and the bolt, several models were analysed. A shape optimisation method was used for further improvement of the best-selected design. The uniaxial tensile loaded the bolts during the analyses. The author showed that the reduction of the stress concentration was feasible by changing a shape of bolts and the nuts. The optimum design was to use the partially hollow bolt in a threaded region and a stepped nut design. An average reduction of stress concentration in the thread reached 61% in comparison with an initial design. The stress calculations were done employing the finite element method

The next group of the journal articles concerns the determination of the stress concentration in the particular thread design and for example, the authors Khaleed Hussain [8] show the 2D FEA analyses of ISO M12 bolt. The authors presented the stress distribution in the thread with the conclusion that the maximum stress is located in the first root of the first thread run for the M12 bolts. The calculations were made for a uniaxial tensile load.

There are many papers concerning a fatigue phenomenon in bolts. Authors focused on the reduction of the thread stresses in order to maximise lifetime of the bolts when cycling loading is presented. Taking into account the topic of the presented work, the most important is the article of O'Brien's and Metcalfe [9], in this paper the authors showed a reviewed of existing knowledge of the bolt/nut design for preventing fatigue failures. The article was an inspiration for starting the presented project. Reading that work a question arose whether there is still a margin for any improvements of the bolt design so that to get better resistance for cycling tangential loading. The paper contains many examples how the designs of the bolts and the nuts should look like so that to maximize their lifetimes. Two of the proposed solutions were tested in the presented project and details of results are shown further in this paper. That article should be mandatory reading for all mechanical engineers due to importance of its content.

The authors Wentzel H [10] analysed ISO M14 class 10.9 bolts loaded by uniaxial load and tangential producing bending. Fatigue tests and advanced finite element analysis were made. Results were remarkable because the fatigue limit in bending was 76% higher than in axial tension. Explanation of this large difference was given using Weibull's weakest link theory, Norberg [11], showing that the defects and a volume effect in the threads are important for the fatigue strength.

The next group of the authors investigated the bolt connection loaded by tangential load but focusing mainly on self-loosening of the bolts/screws. In point of view of presented project, the most interesting is the work [1] where author presented in a very clear way a mechanism of the self-loosening of the bolts due to the tangential load. The author shows the self-loosening is only one possible failure model of the screws and the other one is a fatigue fracture of the screw in the groove of the first thread run in the engagement. This type of failure model is typical when the self-loosening cannot occur for example if an anti-self-loosening prevention feature is implemented.

The presented work is focused on the improvement of the design of the screw loaded by the tangential load; the self-loosening aspect is out of scope of this work. Any implementation of the new design of the screw and the anti-self-loosening features would significantly increase robustness of the connections loaded by the tangential loads.

## Method

The finite element analyses were done using commercial software ANSYS Workbench 17.2 and Hyperworks 14. A solver - Optistruct that is part of Hyperworks package was employed to conduct the structural optimisation. The FE analyses were done using ANSYS and fatigue assessment employing HBM nCode for ANSYS 17.2 software. For CAD model generations, Autodesk Inventor 2016 was utilised with a direct interface to ANSYS Workbench.

The FE analyses depended on a selection of the existing screw designs of the thread runout and an assessment of their structural performance for the specified loads and boundary conditions.

The structural assessment was done comparing the existing stress in the root of the first thread run. Based on this fact, a new proposition of the runout was elaborated (Figure 4), (d), which next was optimised employing the free shape optimisation so that to reduce the stress in the thread. As results, an improve design was obtained Figure 4, (f). As the least step, all models were analysed using non-linear material model with kinematic hardening in order to make an assess of the fatigue lifetime for arbitrary defined loads. The nonlinear material model was applied in order to avoid a simplification - Neuber's rule, Neuber H [12] of estimation of the strain in the thread groove. The fatigue analyses were done for all designs so that to make a comparative assessment of the new design. In details, two defined metrics were compared for all designs. As results, the best screw design was selected in terms of the fatigue resistance.

The analysed undercut/ runout come from:

a – undercut type A – defined by DIN 76-1 norm [13].

b, c – were proposed by authors [9] as an optimal design for an axial load.

d – The version created for the optimisation.

e – The standard design with V-shape runout.

f – The elaborated optimized runout.

## Calculation Models

The finite model is shown in Figure 5 and it consisted of three parts: the hex cap screw, a plate and a base - a part with an internal thread. The load was applied in the model in the following way: the uniaxial tensile load due to pretension and the cycling loads in an axial or tangential direction as a displacement on the plate. Two different boundary conditions were utilized for the finite element analyses and for the structural optimisation; that was forced mainly by limitations of

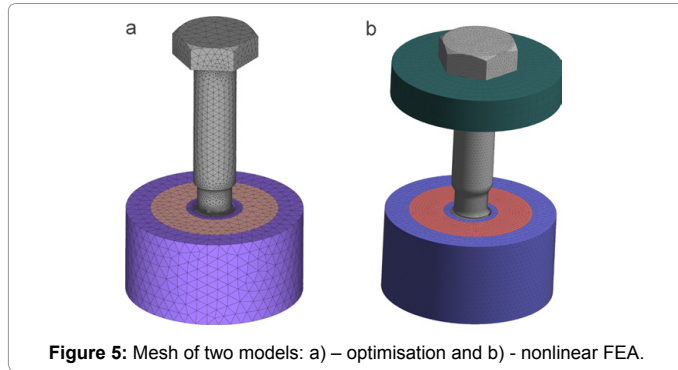

Figure 5: Mesh of two models: a) – optimisation and b) - nonlinear FEA.

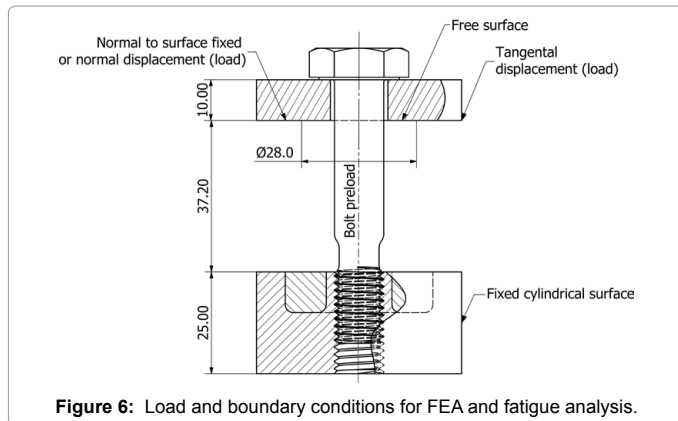

Figure 6: Load and boundary conditions for FEA and fatigue analysis.

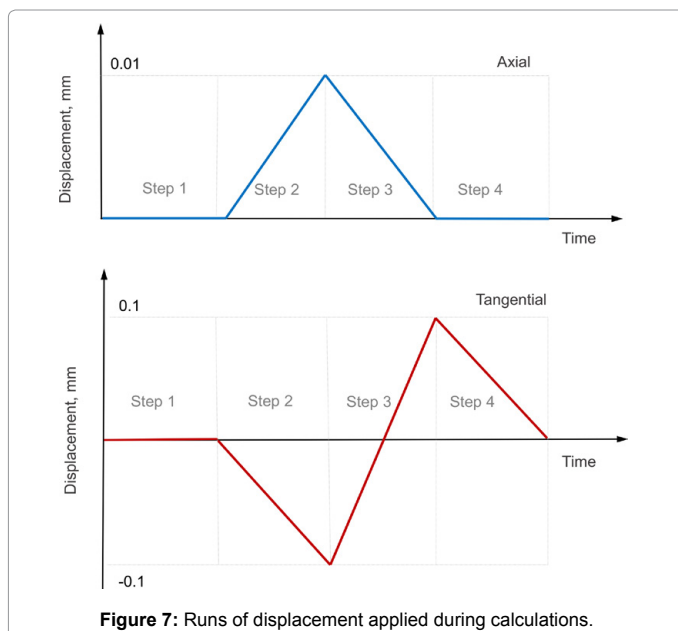

Figure 7: Runs of displacement applied during calculations.

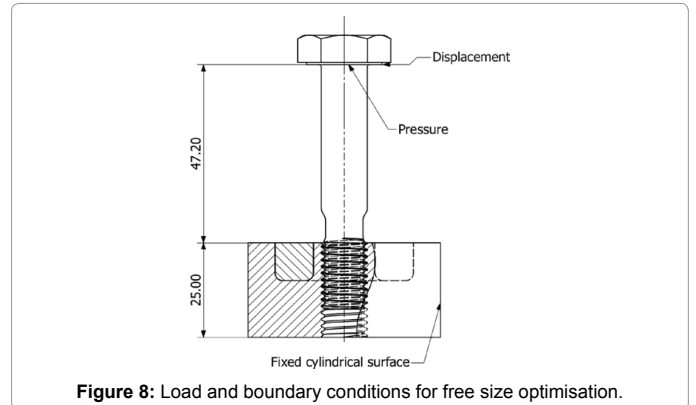

Figure 8: Load and boundary conditions for free size optimisation.

computation time during optimisation phase. Figures 6-8 show details of the boundary conditions and the applied loads.

The model for the optimisation was developed in a way that the maximum stress in the critical thread groove and in the thread runout were compared between the existing designs and basing on that data a new CAD model was elaborated taking into consideration existing knowledge of the best solution. This model was optimised in order to get the optimal shape of the thread runout. As noted previously, the free shape optimisation was employed because the required modifications to get the optimal shape were small due to the design selection done before the optimisation.

The finite element analyses were conducted utilized ANSYS with nonlinear steps in order to take into account the elasto-plastic material behaviour modelled as kinematic hardening. In details, four nonlinear steps were utilized to simulate entire cycle of the load, where the pre-tension of the screw was applied in the first step and in the next steps, the defined load was applied. The determined variable strain distributions were imported to nCode for the fatigue analyses.

## Mesh

All parts were meshed by 10-tetrahedron elements in case of both models. In order to get correct results, the screw model for the FEA and fatigue analyses were meshed in the regions of the maximum stresses with very fine elements with average size of 0.1 mm. The small size of the elements was used to achieve correct stress and strain distributions in the complex geometric feature as the thread. This was required for following the fatigue analysis. The thread runout had the bigger element size of 0.15 mm, because a strain gradient in this region is much smaller than in the thread. The element size of 0.15 mm was used also in a radius between the head and the shank, as in that area, there was stress concentration but with the stress gradient lower than in the thread. The final model contains of about 1 million elements for the FEA model. The model for the optimisation had coarser mesh due to limitation of computation power and thereby very long computational time, that model consisted of about 700 K elements.

## Load and Boundary Conditions

The loads in case of the FEA and the fatigue analyses were applied in four steps in the first the preload of 52.5 kN for the screw M12 class 10.9 and the tangential or axial displacement in the next steps. The defined loads and the boundary conditions reflect a possible real situation, where the tangential load or the axial load could take place. The defined load caused that the screw was loaded by tensile, bending and shear stresses. The runs of the analysed loads are shown

in Figure 7 These loads are defined arbitrary as a part of a definition of the metrics needed for the comparison between the designs. The axial displacement of 0.01 mm reflects an axial force of 2815 N, the tangential displacement of 0.1 mm reflects a situation where a slip between the clamped elements occurs. The loads are selected in the way that the axial load produces failure in high cycling fatigue (HCF) range - plastic stains are not present. For the tangential load, the failure is expected in the low cycle fatigue (LCF) range. These two cases are highly probable in real applications.

For the optimisation phase, the math model is simplified so that to make possible optimisation. Only linear static analyses were employed, this significantly reduced the computation cost, as the optimisation depends on many iterations and the linear step is not computationally expensive.

That model consists of the screw and the base with internal thread only. The load was applied in one linear static step. The load consists of the pressure of 318.4 MPa corresponding to the defined preload of 52.5 kN for the screw M12, class 10.9 and a tangential displacement. The pressure was applied on the bearing surface of the screw head and the tangential load applied as the tangential displacement of 0.1 mm applied on the external edge of the bearing surface see Figure 8.

### Contact

Contact between the thread in the engagement was modelled as a bounded contact, Johnson DH [14] for the model for the optimisation and fictional one with friction coefficient of 0.1 for the FE analyses. Such approach has been forced by very long computation time required by the optimisation in case of a presence of the nonlinear contact.

In Figure 5, it can be seen the base consists of two elements: an insert and the base with the thread. The insert is connected with the base using the bonded contact. The insert was implemented bearing in thoughts a future extension project and for the presented work does not have any influence on the obtained results.

### Material Model

The material of all parts is steel alloy SAE 4340 and it is utilized to produce the class 10.9 screws. The elasto-plastic material behaviour was modelled using kinematic hardening implemented in ANSYS. That model of metal plasticity allows for modelling cycling behaviour including Bauschinger effect [15].

The material characteristic of a monotonic load is shown in Figure 9. With this material model, it was possible to determine strain history in the screw during the load cycling for both load cases (Table 1).

The fatigue properties Table 2 allow for the fatigue analyses in a

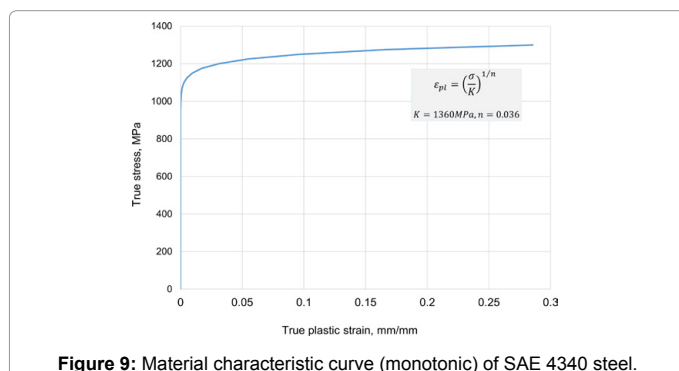

Figure 9: Material characteristic curve (monotonic) of SAE 4340 steel.

Parameters	Values	Remarks
Young's modulus, GPa	207	[4]
Poisson' ratio	0.3	
Tensile strength, MPa	1105	
Yield strength, MPa	1174	
Hardening	Kinematic	Table 2

Table 1: Strength properties of steel SAE 4340.

Material	Values	Remarks
Strength Coefficient, MPa	1127	[4]
Strength Exponent	-0.057	
Ductility Coefficient	7.196	
Ductility Exponent	-0.864	
Cycling Strength Coefficient, MPa	1464	
Cycling Strain Hardening Exponent	0.118	

Table 2: Strain-life properties of steel SAE 4340.

low cycling and high cycling fatigue range. The presented material data comes from the book [4] where the authors presented results of a test of a specimen made of SAE 4340 steel.

Unfortunately, they concern an ideal smooth specimen, this has influence on an interpretation of the obtained fatigue results and this aspect is discussed in the chapter – fatigue analysis.

### Optimisation

As stated, the model for the optimisation- Figure 4d was designed basing on the comparison of stress levels in the thread between the analysed designs Figures 4a, 4b, 4c and 4e. Through this, the needed modifications of the design were small so that to get the optimal shape. Consequently, the free shape optimisation was employed, which can produce small modifications of the mesh limited by element quality. The elements cannot have any shape; they have to meet criteria determined by quality element metrics.

The optimised region was defined as the full thread runout (Figure 10). There, the software has possibility to change locations of the nodes in order to minimize the objective function. The movement of the nodes was constrained so that to get a cylindrical shape after the modifications. This is an evident requirement since the bolt must be round in any sections.

The goal of optimisation was to minimize the maximum von Mises stress in thread (the groove of the first thread run in the engagement). As it was noted previously, this location has greatest stress. This is visible after the made FE analyse and it is also confirmed by the author of the work [1].

The optimisation was carried out employing Hypermesh as the pre-processor, Optistruct as the solver and HyperView as the postprocessor. The software is a part of the finite element package Hyperworks 14.0 from Altair Engineering. A selection of the software for the project was done on the ground of renown, which Hyperworks has. It should be mentioned that the selection was excellent; the tools met all the expectations in terms of stability and result correctness.

As stated, the optimisation was done using only the linear elastic model of the material with the static linear analysis. Unfortunately, the nonlinear analyses due to computation time were not included in the optimisation part. The proposed approach appears to be correct taking into account that as next steps the static nonlinear calculations were completed.

## Fatigue Analysis

The fatigue analysis were done to complete the comparison between the analysed designs of the runout. Two cases of cycling loading were analysed, the first one, cycling tangential displacement applied on the plate with the constant pre-load and the other one, cycling axial displacement applied on the plate with the constant pre-load – (Figure 7). As noted, the lifetimes for those two load cases were defined as the metrics for the assessment of the designs of the thread runouts.

The fatigue analyses were done employing stain-life approach in order to take into account low-cycling fatigue where plastic strain has dominant role. The analysis was done using nCode. The parameters of the fatigue analyses are shown in Table 3.

To complete the fatigue analyses, reliable fatigue material properties are needed, the high quality input data are causal for this type of assessment. For that reason, the presented data – Table 2 come from the work [4] and they are based on a done test. However, they could produce results, which are affected by an error for instance due to different surface roughness or material properties between test specimens and real parts. Unfortunately, the presented work depends

Parameter	Value
Stress combine method	Critical plane [16]
Mean stress correction	Smith Watson Topper
Multi axial assessment	Yes
Elasto-plastic correction	None, (plastic stains calculated in FEA)
Required certainty of survival	50%
Material fatigue properties	Table 2
Surface roughness	Polished

Table 3: Parameters used in fatigue analyses.

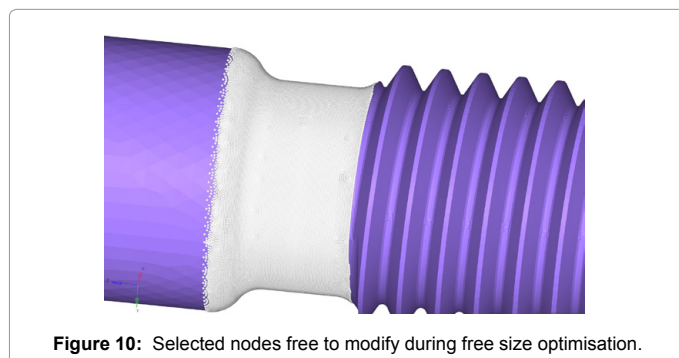

Figure 10: Selected nodes free to modify during free size optimisation.

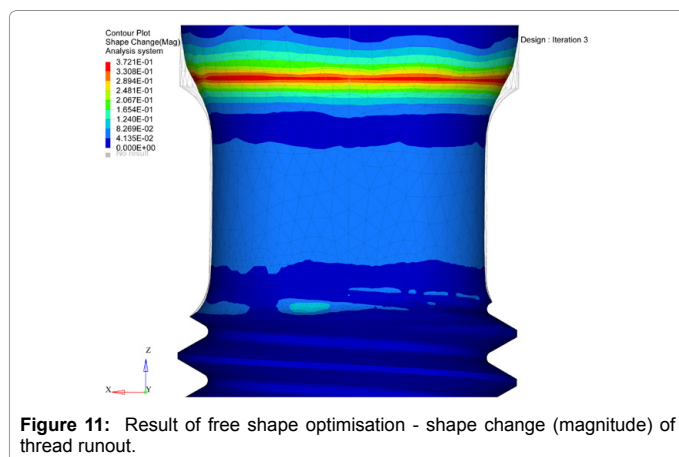

Figure 11: Result of free shape optimisation - shape change (magnitude) of thread runout.

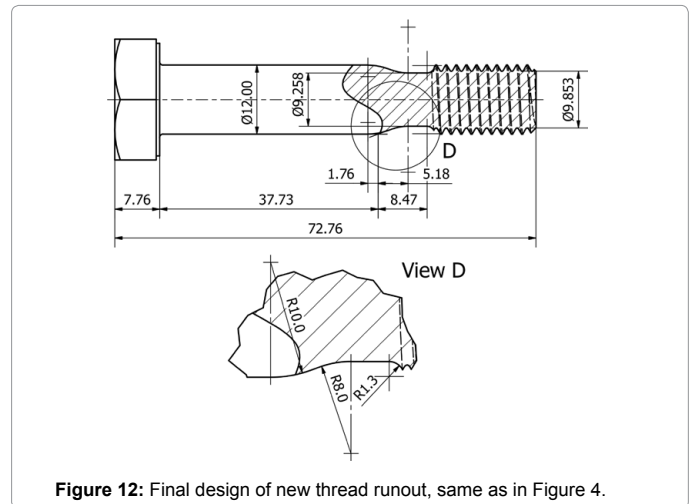

Figure 12: Final design of new thread runout, same as in Figure 4.

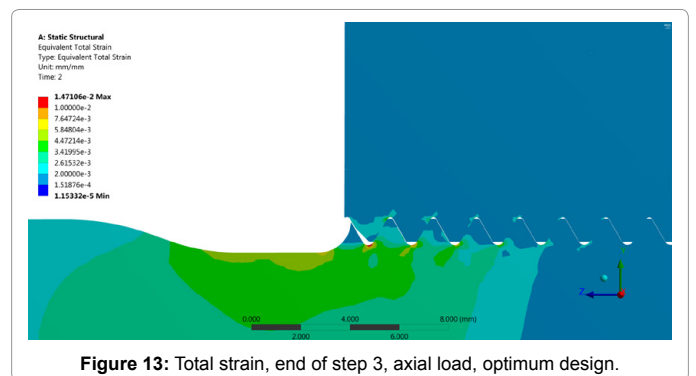

Figure 13: Total strain, end of step 3, axial load, optimum design.

on the comparison between the different designs only and it could be assumed that the same errors are made for all analysed cases. Therefore, a relationship between the results could be the same as for real fatigue tests but the real lifetime might be different from this one calculated in the presented project. Nevertheless, the conclusions about the fatigue resistance of the particular designs will be valid also for the real parts assuming the same manufacturing defaults for those parts.

Consequently, it should be emphasized that due to statistically determined fatigue phenomenon only real fatigue tests can give an answer if a designed part meets a lifetime target. Numerical tools can significantly reduce design time selecting a most appropriate solution for a particular application/ load duty cycles, but they cannot replace fully physical tests.

## Results and Discussion

The results of the investigation are presented in the following tables and figures so that to make the outcomes more visible for a reader. The results were unexpectedly good and in line with expectations, there is possibility to improve the existing design of the screws loaded by the transversal load. The developed design brings a significant improvement in terms of fatigue lifetime in the tangential and axial cycling loads. The details of the results are presented in the following paragraphs focusing on a comparison with the existing designs.

The new improved shape of the screw runout is shown in Figure 11 and basing on this result the new design of the screw was developed – the design (Figure 12). Then all designs were investigated so that to determine limits of the lifetime for both analysed loads case so that to make comparison. The results of comparison are presented in Table 4.

The critical region of the screws loaded with the axial load is well known as the groove in the first turn of the thread in the engagement. In the case of the presented analysis, the critical region is also the first thread groove and Figures 13 and 14 show indeed this area. The obtained results confirm that the FE analyses give the correct location of the critical points. In case of the analysed axial load, the total strain level is low as the load was defined to get the failure in the HCF range.

The tangential load creates additional stress in the first thread groove in the engagement. That load scenario can be easily compared with a cantilever beam loaded with a concentrated load at a beam end. A maximum bending stress is located at a fixation of the beam. In the case of the screw, this fixation is thread in the engagement. Figure 14 shows this effect visibly – the bending of the screw causes an asymmetric distribution of the total strain. It can be seen, that the strain level is greater than in the previous case, because of the done load selection so that to get the failure in the LCF range. To reduce stresses/strains at that point, assuming the same load, geometry modifications of the thread runout

Design Figure 4	Lifetime, cycles		Location of critical area
	Tangential load	Axial load	
a	9.371E3	1.138E8	Groove of first thread turn
b	4.696E3	2.251E7	same
c	4.819E3	2.245E7	same
d	5.990E3	2.886E7	same
e	3.439E3	1.514E7	same
f	1.040E4	1.561E8	same

Table 4: Results of analysis, comparison between different designs.

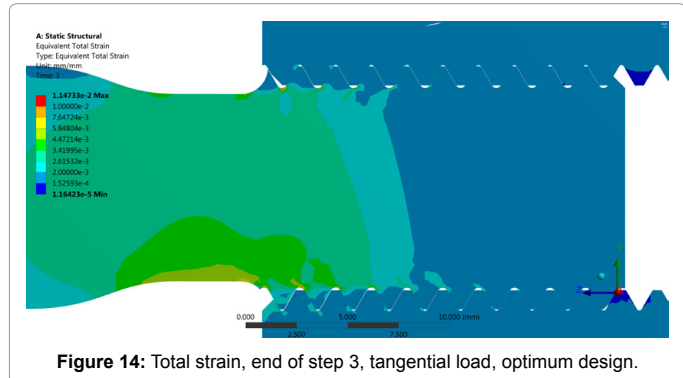

Figure 14: Total strain, end of step 3, tangential load, optimum design.

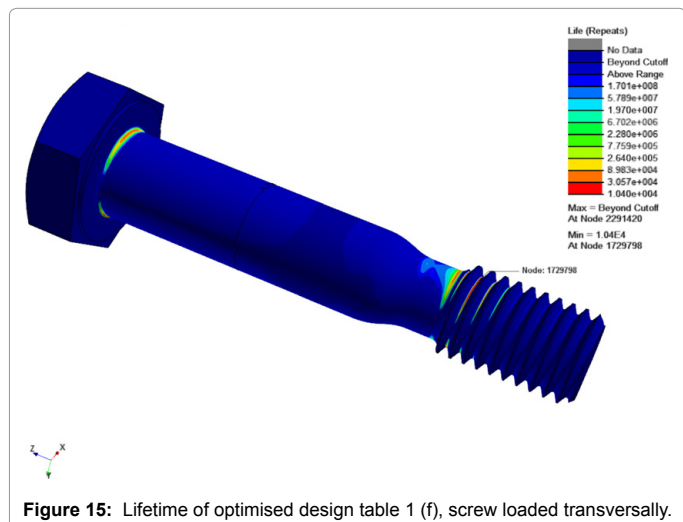

Figure 15: Lifetime of optimised design table 1 (f), screw loaded transversally.

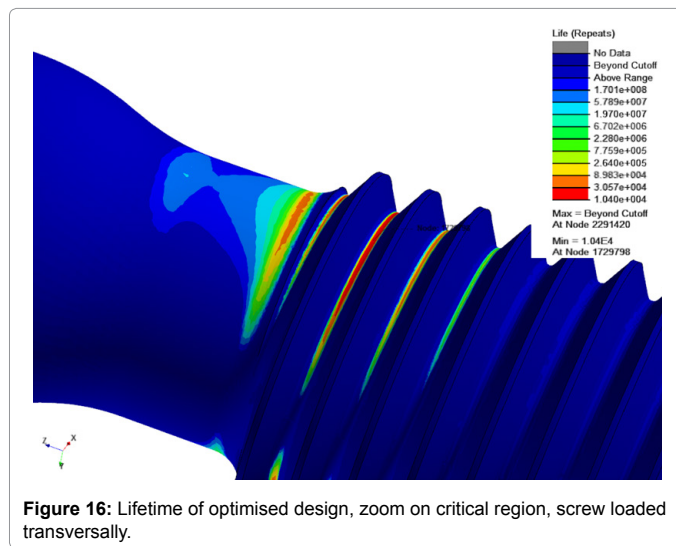

Figure 16: Lifetime of optimised design, zoom on critical region, screw loaded transversally.

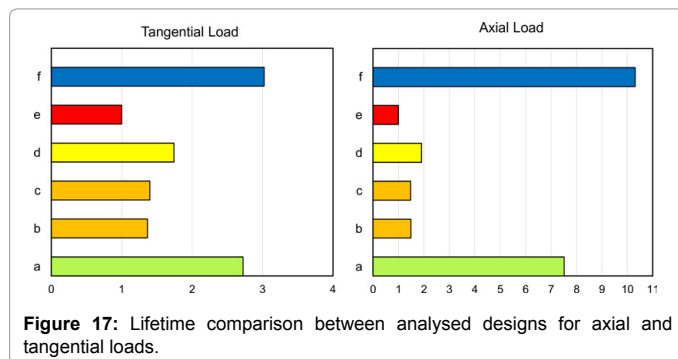

Figure 17: Lifetime comparison between analysed designs for axial and tangential loads.

or/and of the thread itself can be done. As the thread is normalized it cannot be changed. There is only one solution that exists, namely to change of the thread runout. Therefore, the geometry changes of the runout were done employing the structural optimisation. It should be pointed out, that it is not possible to eliminate completely those stress concentrations even with the implemented modifications.

Thus, the stress concentration is still in the same places for both load cases and only the level of the strains was reduced by the implementation of the new runout. As results show, the lifetime of the new design is significantly longer than the lifetime of the other designs (Table 4). Figure 15 shows the lifetime of the new screw loaded by the transversal cycling load.

The obtained lifetime of 10400 cycles is the greatest from all analysed designs (Table 4). As was expected, the developed thread runout causes the reduction of stresses/strains in the thread groove what translates directly to the greater lifetime. In Figure 16, a zoom of that critical region can be seen and it can be undoubtedly understood that the lifetime limitation of the screw is the strain level in the groove in the first turn of the thread engagement.

For that reason, a failure fracture of the screw occurs in that section and indeed this is confirmed by the literature source [1]. Usually, the fracture of the screw loaded with transversal cycling load occurs in the first groove in the thread engagement. Less likely, it can happen at the connection between that the shank and the head. The same failures mode could occur for the screws loaded with axial cycling load. This is confirmed also by the done analyses.

Figure 17 and Table 4 show the comparison between the obtained results of the analysed designs. It can be seen that the developed design of the tread runout gives the best results for both load cases for the transversal and axial loads and the improvements are significant as Figure 17 shows. The proposed design has adequately 11% and 37% greater the lifetime for the axial and transversal loads than the best existing design. In comparison with the most popular runout – the V type, the lifetime are adequately 3 and 10 times better for the transversal and axial loads. Those are really the promising results before final validation tests.

## Conclusions

Based on the conducted analyses the following conclusions can be drawn:

- The results of studies confirmed the made assumption that, there is still a margin for the improvement of the existing screw design and as it turns out, the developed design gives excellent structural strength.
- The goal of the project was met - the new design of the thread runout was proposed giving significantly greater lifetime than designs proposed by others authors and standards. Moreover, the lifetime of the analysed transversal load and as well as the axial load is significantly greater than for the other designs. The great structural improvement exceeds the initial expectation.
- The implementation of the design should not be any problem due to simple geometry of the runout.
- Usage of different engineering tools like the finite element calculations, the free shape optimisation and the fatigue analysis can significantly contribute to the improvement of the design process giving possibility to develop new innovative designs in short time.
- The real fatigue testing with the tangential and axial load is required to demonstrate finally that the developed design gives benefit in terms of its lifetime. As a next step of the project, fatigue tests of the developed design will be conducted to confirm the theoretical findings.

## References

1. Hashimura S (2007) Influences of various factors of bolt tightening on loosening-fatigue failure under transverse vibration.
2. Altair Engineering I (2015) Practical aspects of structural optimization: A study guide, (2nd edn). Altair Engineering, Inc.
3. SAE (1996) Torque-tension tightening for metric series fasteners SAEJ170M.
4. (1987) 43 NiCr 7 9 SAE 4340. In Mater Sci Monogr.
5. Pedersen NL (2013) Optimization of bolt thread stress concentrations. Arch Appl Mech 83: 1-14.
6. Govindu N, Jayanand Kumar TSV (2015) Design and optimization of screwed fasteners to reduce stress concentration factor. J Appl Mech Eng.
7. Lee CH, Kim BJ, Han SY (2014) Mechanism for reducing stress concentrations in bolt-nut connectors. Int J Precis Eng Manuf 15: 1337-1343.
8. Khaleed Hussain MT, Samad Z, Suhaib S, Uthman AR (2008) Analysis of stress concentration factor in bolted joint using finite element method. Electron J Univ Malaysia 3.
9. O'Brien MJ, Metcalfe RG (2009) High strength engineering fasteners: design for fatigue resistance. J Fail Anal Prev 9: 171-181.
10. Wentzel H, Huang X (2015) Experimental characterization of the bending fatigue strength of threaded fasteners. Int J Fatigue 72: 102-108.
11. Norberg S, Olsson M (2007) The effect of loaded volume and stress gradient on the fatigue limit. Int J Fatigue 29: 2259-2272.
12. Neuber H (1963) Investigation of the distribution of tension in notched construction elements. Report no ASD-TDR-63-361 AD 410529.
13. DIN (2004) Din 76-1, thread run-outs and thread undercuts for ISO metric threads in accordance with Din 13-1.
14. Johnson DH (2002) Principles of simulating contact between parts using ANSYS. Penn State-Erie Univ Erie, Pennsylvania 12.
15. Buciumeanu M, Palaghian L, Miranda AS, Silva FS (2011) Fatigue life predictions including the Bauschinger effect. Int J Fatigue 33: 145-152.
16. Socie D (1993) Critical plane approaches for multiaxial fatigue damage assessment. ASTM Spec Tech Publ 1191:7-36.

Citation: Kedziora S (2017) Optimal Design of Cap Screw Thread Runout for Transversal and Axial Loads. J Appl Mech Eng 6: 250. doi: [10.4172/2168-9873.1000250](https://doi.org/10.4172/2168-9873.1000250)

### OMICS International: Open Access Publication Benefits & Features

#### Unique features:

- Increased global visibility of articles through worldwide distribution and indexing
- Showcasing recent research output in a timely and updated manner
- Special issues on the current trends of scientific research

#### Special features:

- 700+ Open Access Journals
- 50,000+ Editorial team
- Rapid review process
- Quality and quick editorial, review and publication processing
- Indexing at major indexing services
- Sharing Option: Social Networking Enabled
- Authors, Reviewers and Editors rewarded with online Scientific Credits
- Better discount for your subsequent articles

Submit your manuscript at: <http://www.omicsonline.org/submission>